

CONTAINER **XXL**

LAGERCONTAINER XXL | storage container | conteneur de stockage
Montageanleitung | Mounting Instructions | Instructions de montage

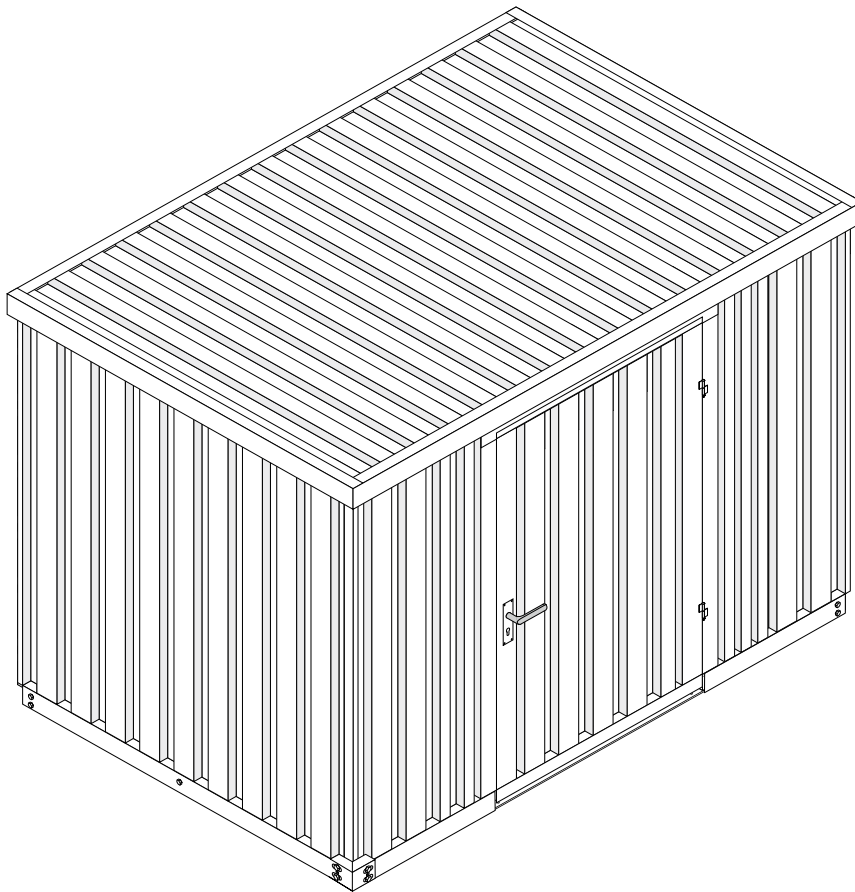

WARNHINWEISE

WARNINGS | AVERTISSEMENTS



ACHTUNG!

Bitte lesen und beachten Sie vor Beginn des Aufbaus diese Montageanleitung und die nachfolgenden Warnhinweise.

1. Ein sicherer, fester und ebener Untergrund ist die Voraussetzung für den ordnungsgemäßen Aufbau der Container.
2. Für die Verankerung werden Punktfundamente benötigt. Entsprechende Pläne erhalten Sie auf Anfrage.
3. Das Tragen von Schutzhandschuhen wird dringend empfohlen, da die Elemente scharfkantig sein können.
4. Eine Schutzbrille ist im Besonderen beim Entfernen der Transportgurte zu tragen, da diese unter Spannung stehen.
5. Verwenden Sie ausschließlich sicheres und intaktes Werkzeug.
6. Die Montage des Containers kann ernste und lebensgefährliche Verletzungen durch Einklemmen oder umfallende Teile zur Folge haben. Während der Montage ist eine Schutzausrüstung zu tragen.
7. Mindestens zwei Personen sind bei der Montage des Containers erforderlich.
8. Der Aufbau muss von sachkundigem Personal anhand dieser Montageanleitung erfolgen.



ATTENTION!

Before starting assembly, please read and follow these assembly instructions and the following warnings.

1. A safe, solid and even subsoil is the prerequisite for a proper installation of the container.
2. A foundation is required for anchoring. Corresponding plans are available on request.
3. Wearing protective gloves is urgently recommended, because the elements can be sharp edged.
4. Protective glasses are to be worn especially when removing the transportation belts, because they are tightened strongly.
5. Use only exclusively sure and intact tools.
6. The assembly of the container may lead to serious or fatal crushing injuries from parts tipping over. During the assembly, wear protective equipment.
7. At least two persons are required for the assembly of the containers.
8. The assembly must be carried out properly according to these assembly instructions by experienced personnel.



AVERTISSEMENT!

Veuillez lire et respecter ces instructions de montage et les avertissements suivants avant de commencer le montage.

1. Une surface plane et solide est la condition préalable pour effectuer un montage correct du conteneur.
2. Une fondation est nécessaire pour l'ancrage. Les plans correspondants sont disponibles sur demande.
3. Il est fortement recommandé de porter des gants de protection car les éléments peuvent avoir des arêtes vives.
4. Le port des lunettes de protection est particulièrement conseillé en enlevant les sangles, qui sont fortement tendues.
5. Utilisez exclusivement des outils sûres et en bon état.
6. Le montage du conteneur peut être source d'accidents et de blessures très graves (pièces tombantes ou pincements). Le port d'équipements de sécurité est nécessaire pendant le montage.
7. Au moins deux personnes sont nécessaires pour le montage du conteneur.
8. Le montage est à effectuer par des personnes qualifiées selon ces instructions ci-après.

KONTROLLE

CHECK | CHECK-LIST

- 1 **Seitenwand** | side panel | paroi latérale
- 2 **Rückwand** | back panel | paroi arrière
- 3 **Türwand & Türblatt** | panel including door | paroi avec porte
- 4 **Dach** | roof | toit
- 5 **Dachhalteklammer** | roof securing clamp | fixation du toit
- 6 **Türgriffe** | door handle | poignée de porte
- 7 **Schlüssel** | key | clé
- 8 **Befestigungswinkel** | mounting bracket | équerre de fixation
- 9 **Eckwinkel** | corner angle | cornière d'angle
- 10 **Flachrundschaube** | round-head screw | vis à tête plate

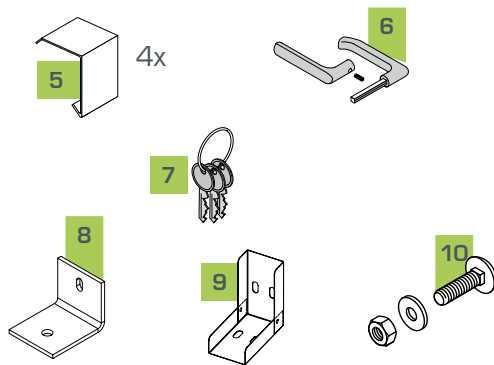
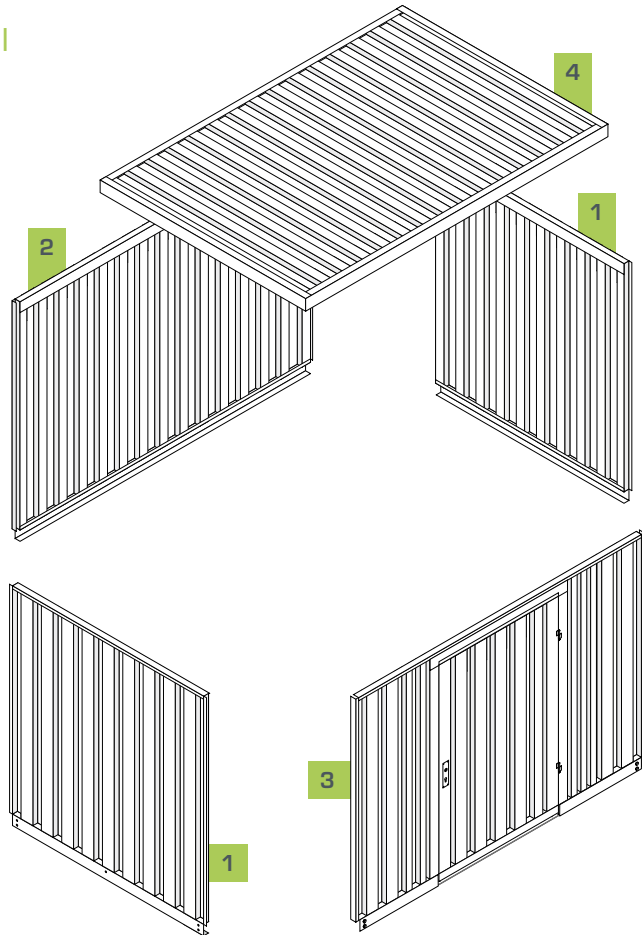

HINWEIS! Verankerungsmaterial muss vom Kunden bereitgestellt werden.
NOTICE! Anchoring material must be provided by customer.
ATTENTION! Le matériel d'ancrage doit être fourni par le client.

Sie benötigen | you need | vous nécessitez

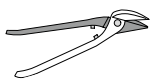

Bleischere
plate shears
cisaille à tôle

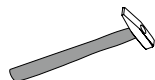

Hammer
hammer
marteau



Seitenschneider
cutter
pince coupante



Inbusschlüssel SW3
hex key
clé mâle à six pans

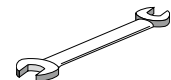

Maulschlüssel SW13
open-end wrench
clé à fourche

OPTIONALES ZUBEHÖR

OPTIONAL ACCESSORIES | ACCESSOIRES EN OPTION

- A** Kranaufhängung | suspension eye | œillet de suspension
- B** Einbauregal | shelf | rayonnage
- C** Schlauchaufhängung | hose bracket | support de tuyau
- D** Gerätehalter | device hook | crochet pour outils
- E** Elektromodul | electrical module | module électrique
- F** Geräteleiste | tool rail | support pour outils



HINWEIS! Elektromodul und Geräteleiste VOR Montage des Daches anbringen.

NOTICE! Install electrical module and tool rail BEFORE fixing the roof.

ATTENTION! Fixez le module électrique et le support pour outils AVANT le montage du toit.

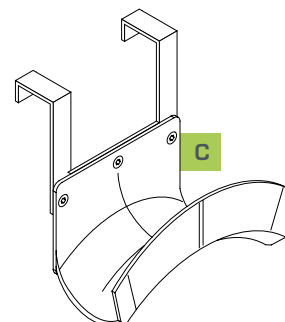
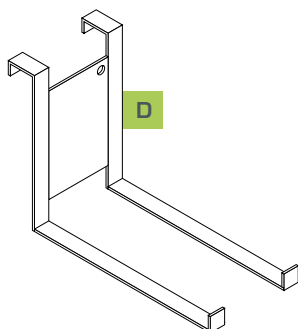
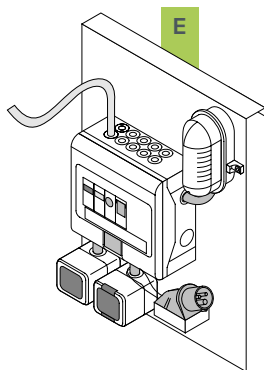
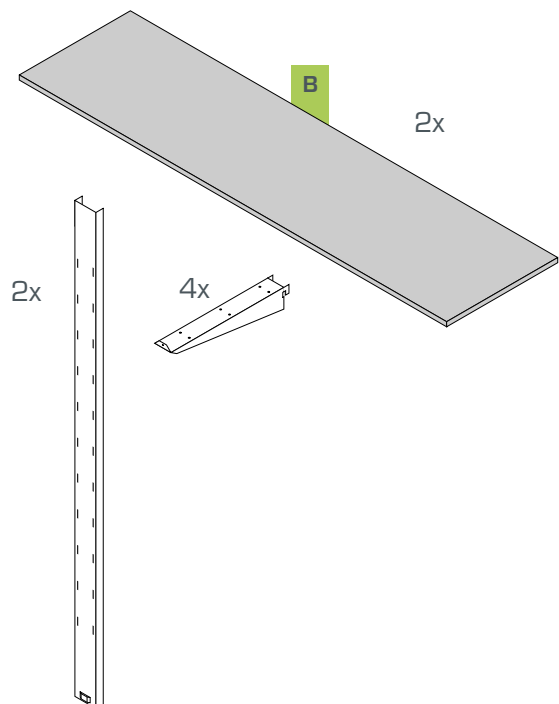
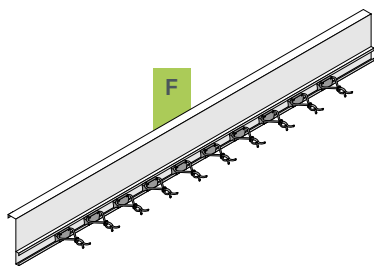
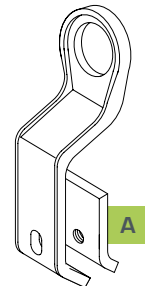

M1 Auspacken unpacking | déballage



VORAUSSETZUNG! Tragfähiger, ebener Untergrund (Fundament).

PREREQUISITE! Stable, even subsoil (foundation).

CONDITION PRÉALABLE! Fondation adaptée et plat (fondation).

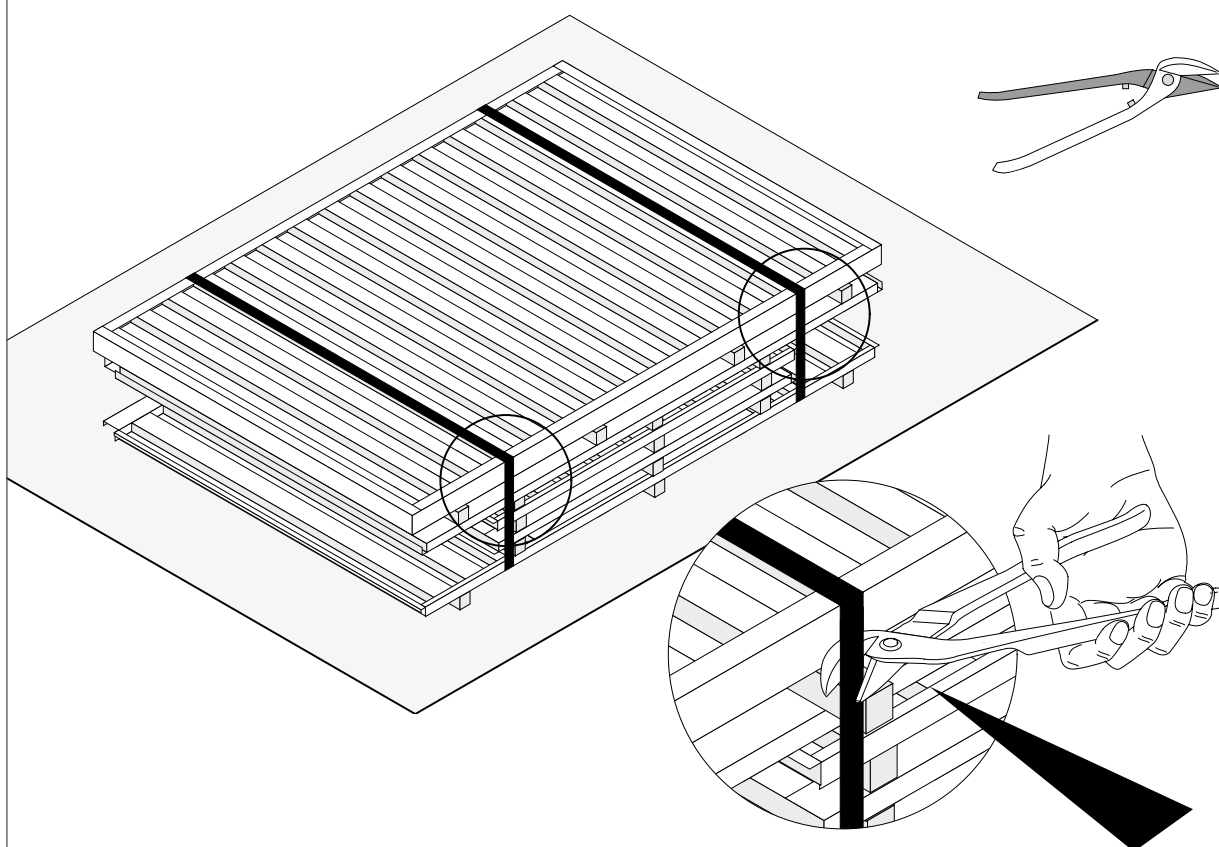

VORSICHT! VERLETZUNGSGEFAHR.
SCHUTZAUSRÜSTUNG TRAGEN.

CAUTION! RISK OF INJURY.
WEAR PROTECTIVE EQUIPMENT.

ATTENTION! RISQUÉ DE BLESSURE.
PORTER UN ÉQUIPEMENT DE PROTECTION.



M2 Seitenwand & Rückwand

side panel & back panel | paroi latérale & paroi arrière

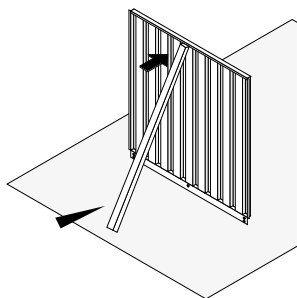

TIPP! Für mehr Stabilität und bessere Absicherung einen Stützbalken verwenden

(nicht im Lieferumfang enthalten).

HINT! Use a strut to increase stability and safety (not included).

CONSEIL! Utilisez une poutre pour améliorer la stabilité et la sécurité (non-fournie).

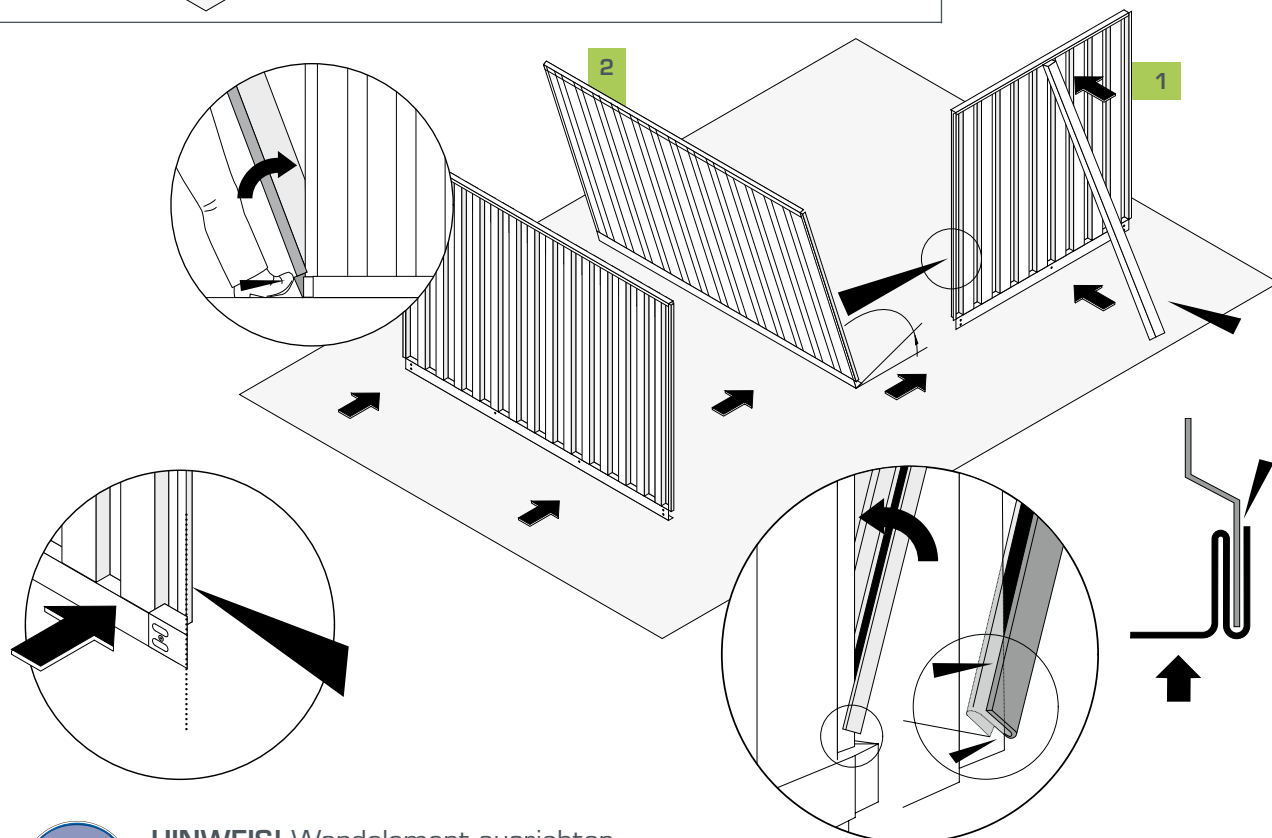

HINWEIS! Wandelement ausrichten.

NOTICE! Align panel element.

ATTENTION! Ajustez les parois.

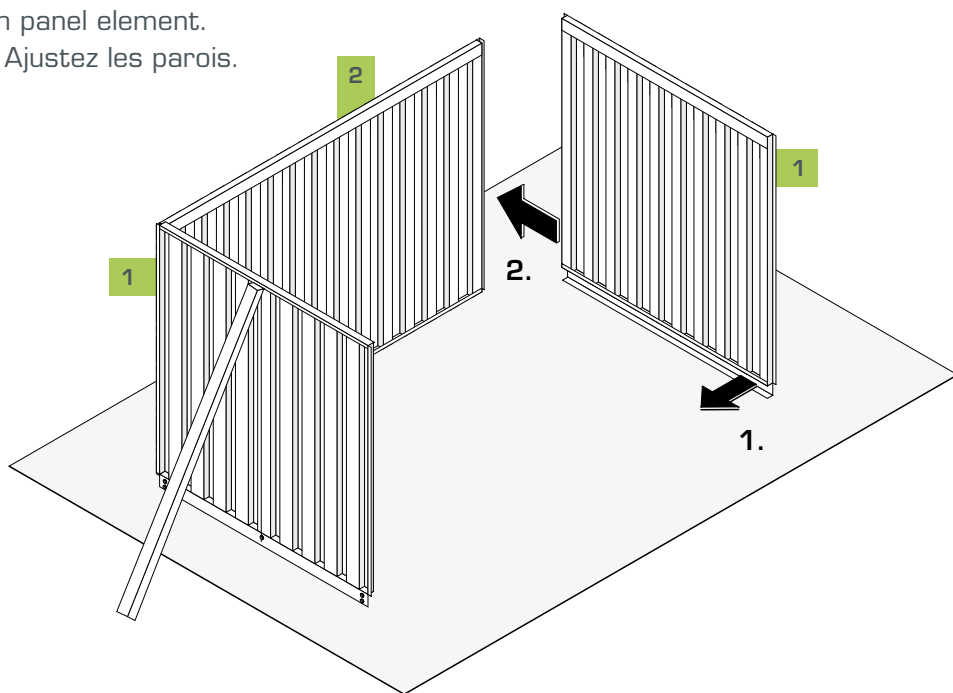

M3 Türwand & Türblatt
panel including door | paroi avec porte

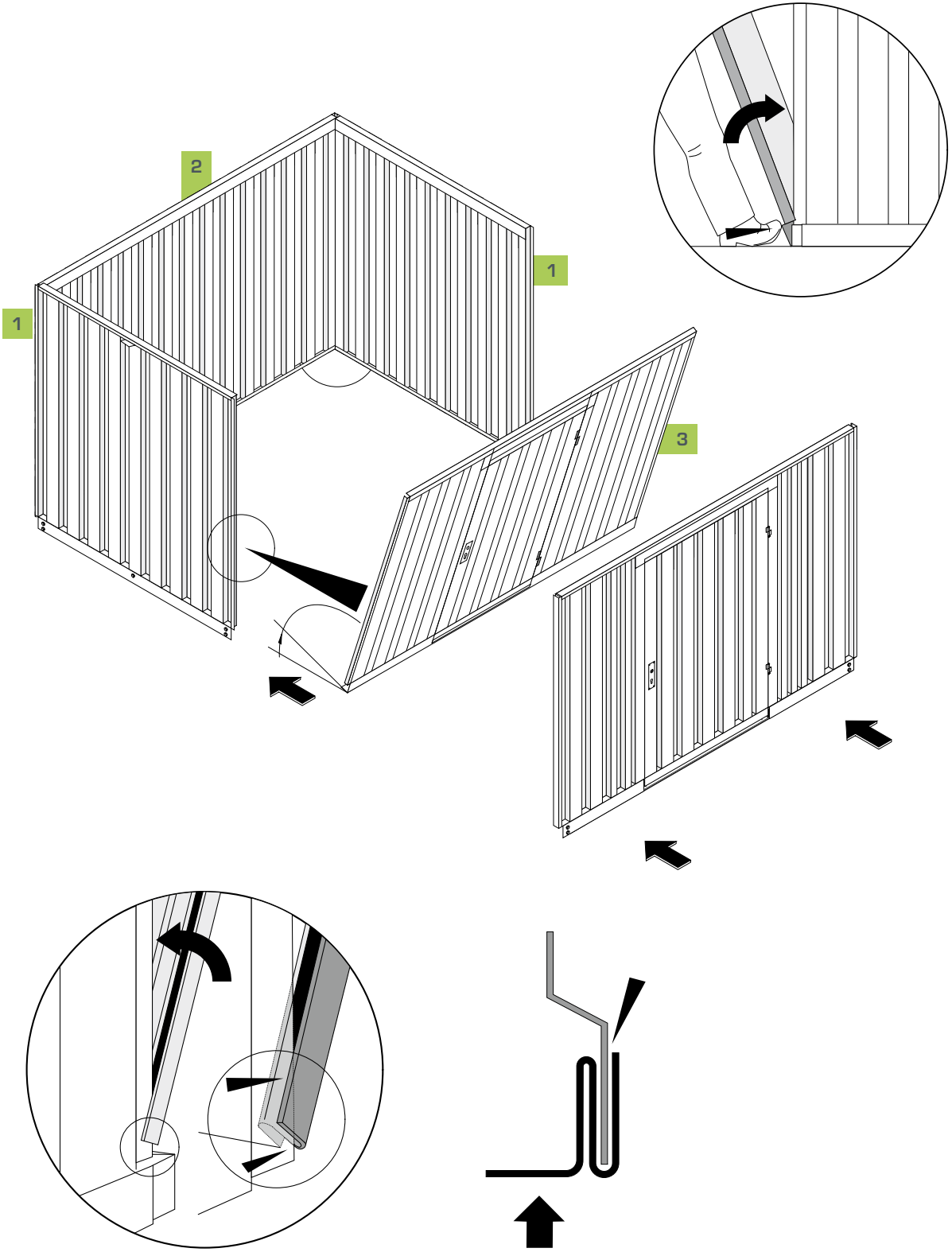

M4 Türgriffe

door handle | poignée de porte

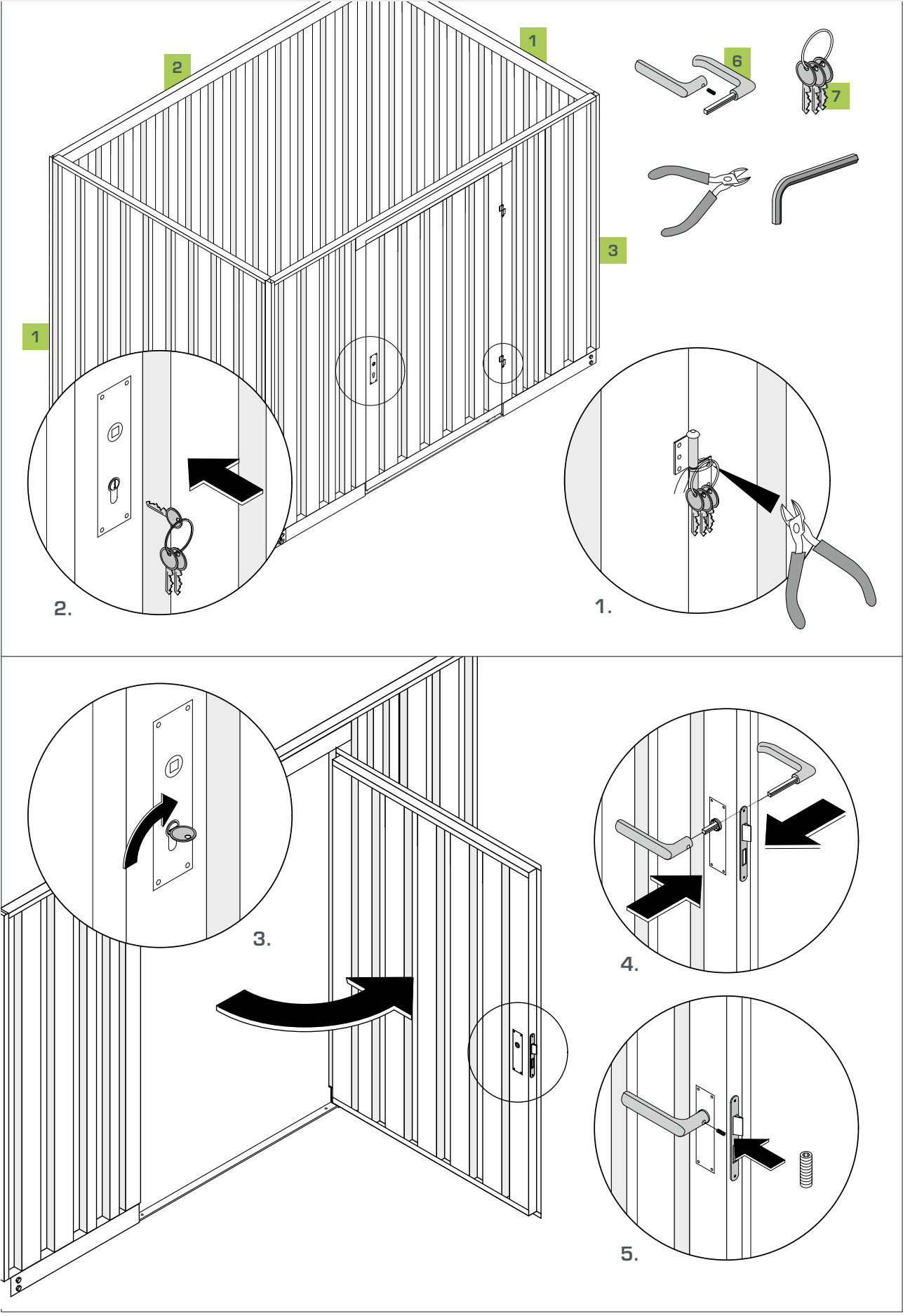

M5 Eckwinkel

corner angle | cornière d'angle

TIPP! Für leichteres Einführen der Schrauben die Löcher (Ø 5 mm) vorbohren.
HINT! For easy mounting, predrill the holes (Ø 5 mm) before inserting the screws.
CONSEIL! Pré-percer les trous (Ø 5 mm) facilite la pose des vis.

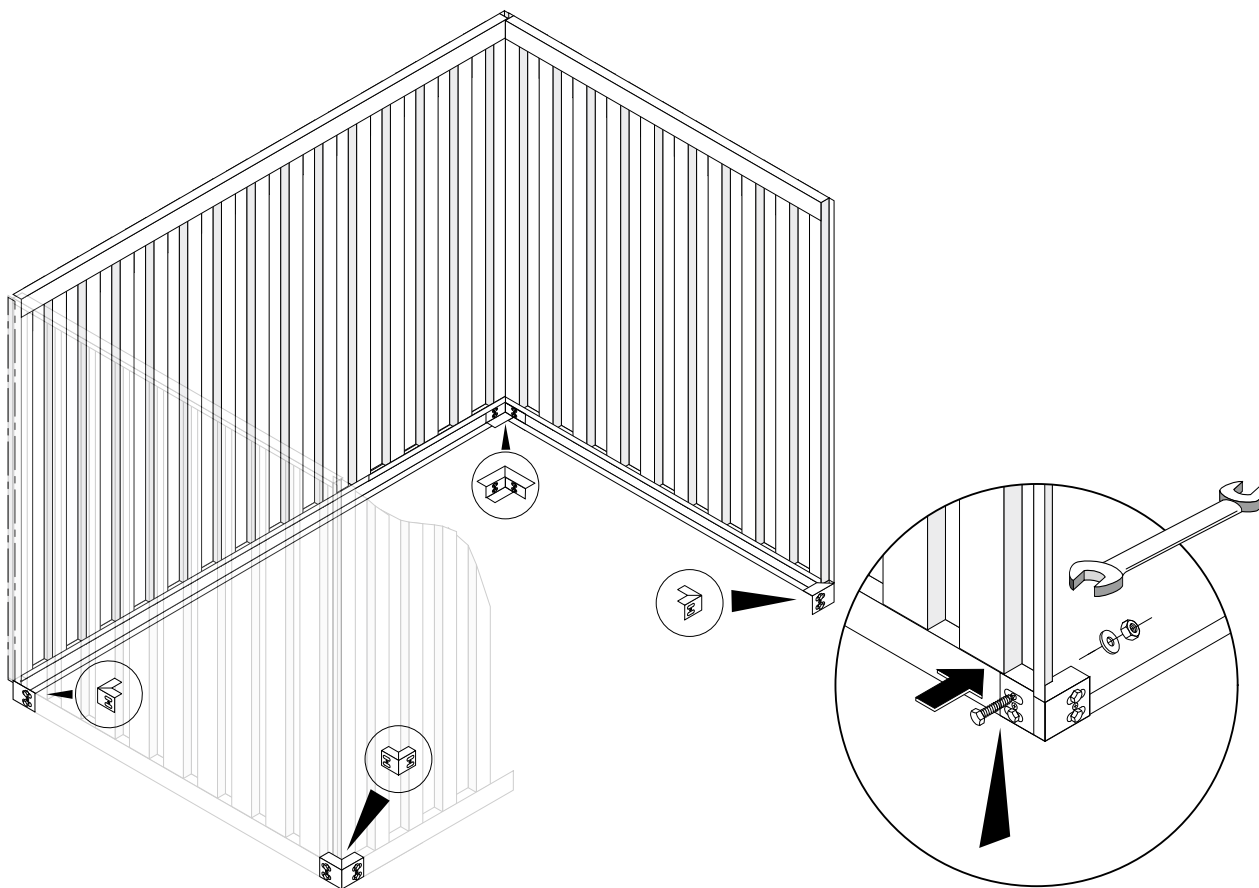
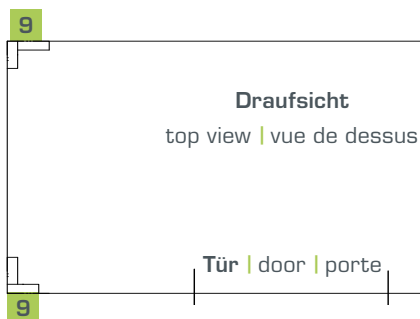
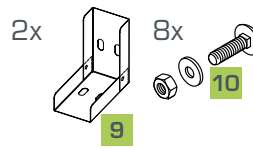
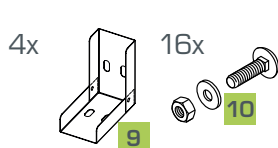

M6 Elektromodul & Geräteleiste (optional)

electrical module & device hook | module électrique & crochet pour outils

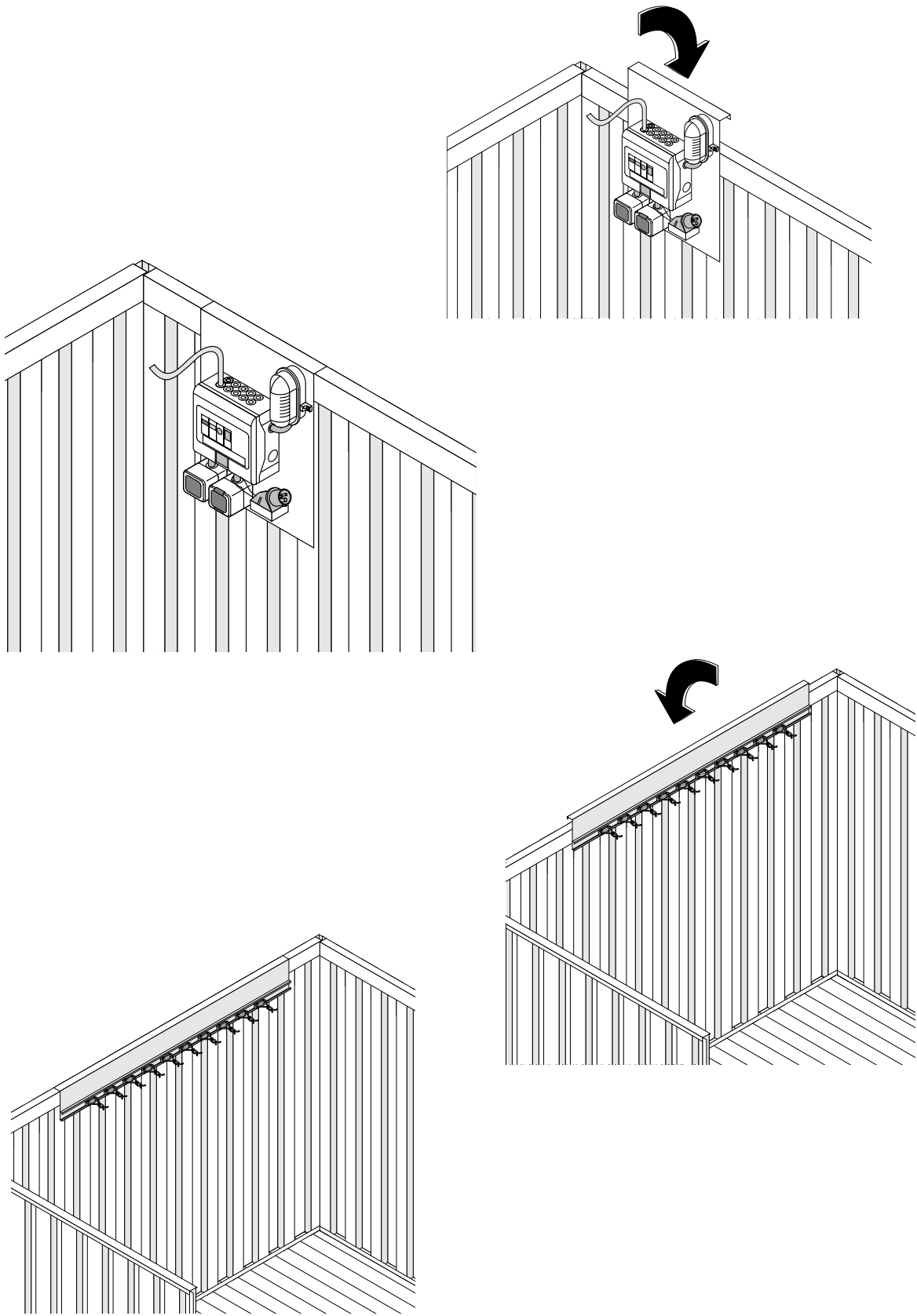

M7 Dach
roof | toit

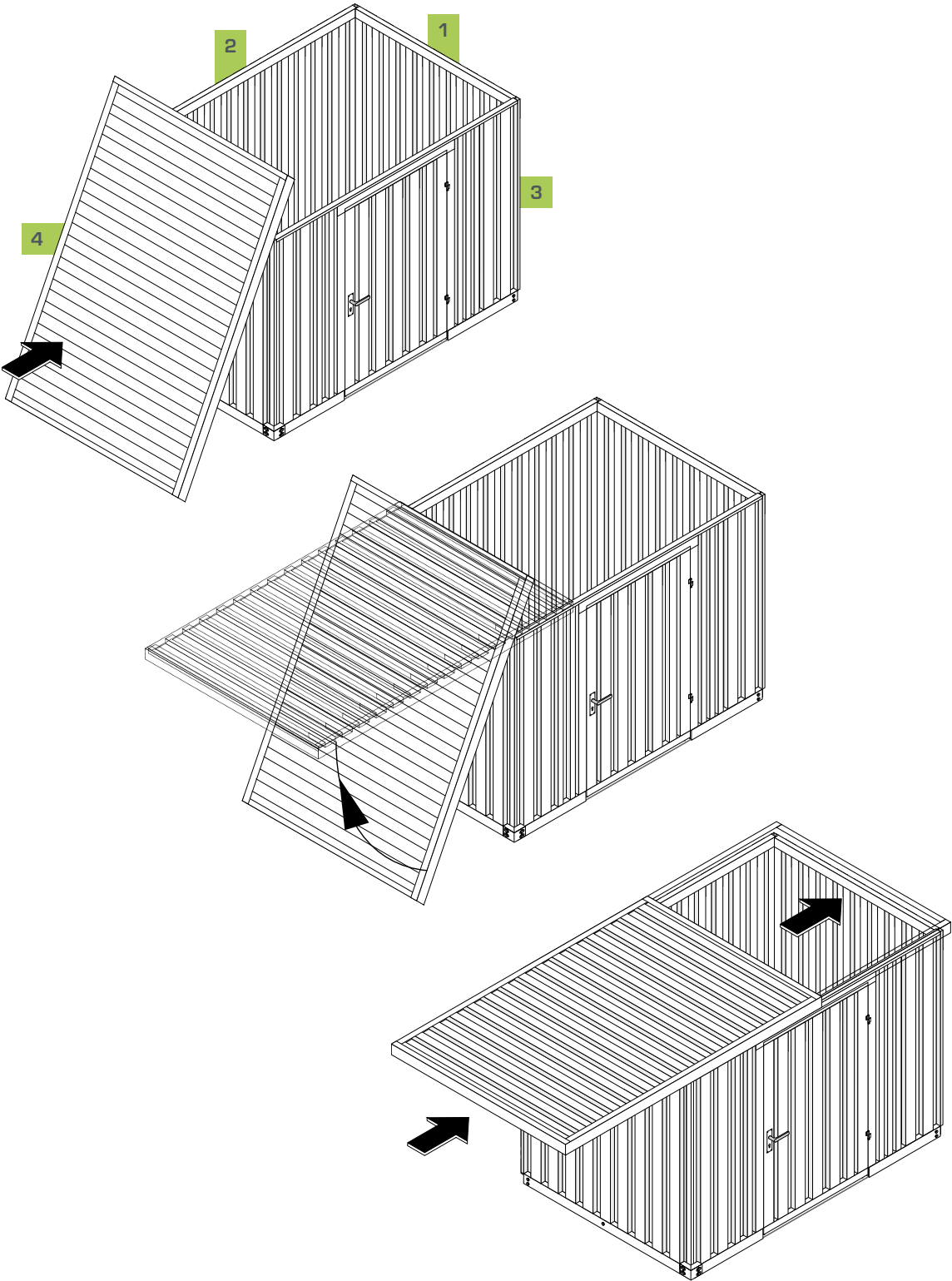

M8 Dachhalteklammer

roof securing clamp | fixation du toit



HINWEIS! Montage im Innenraum.
NOTICE! Mounting inside the container.
ATTENTION! Montage de l'intérieur.

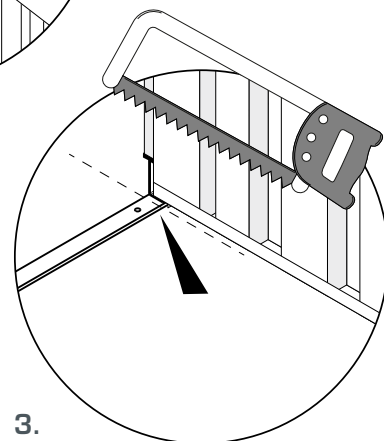
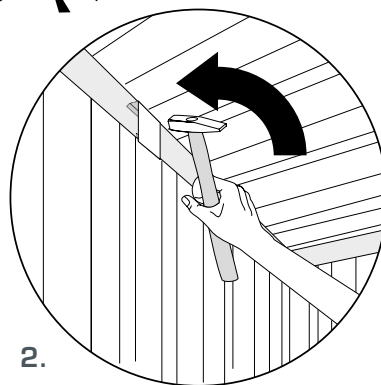
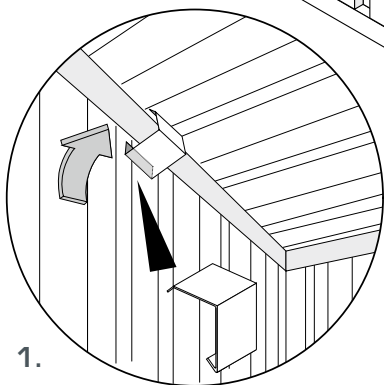
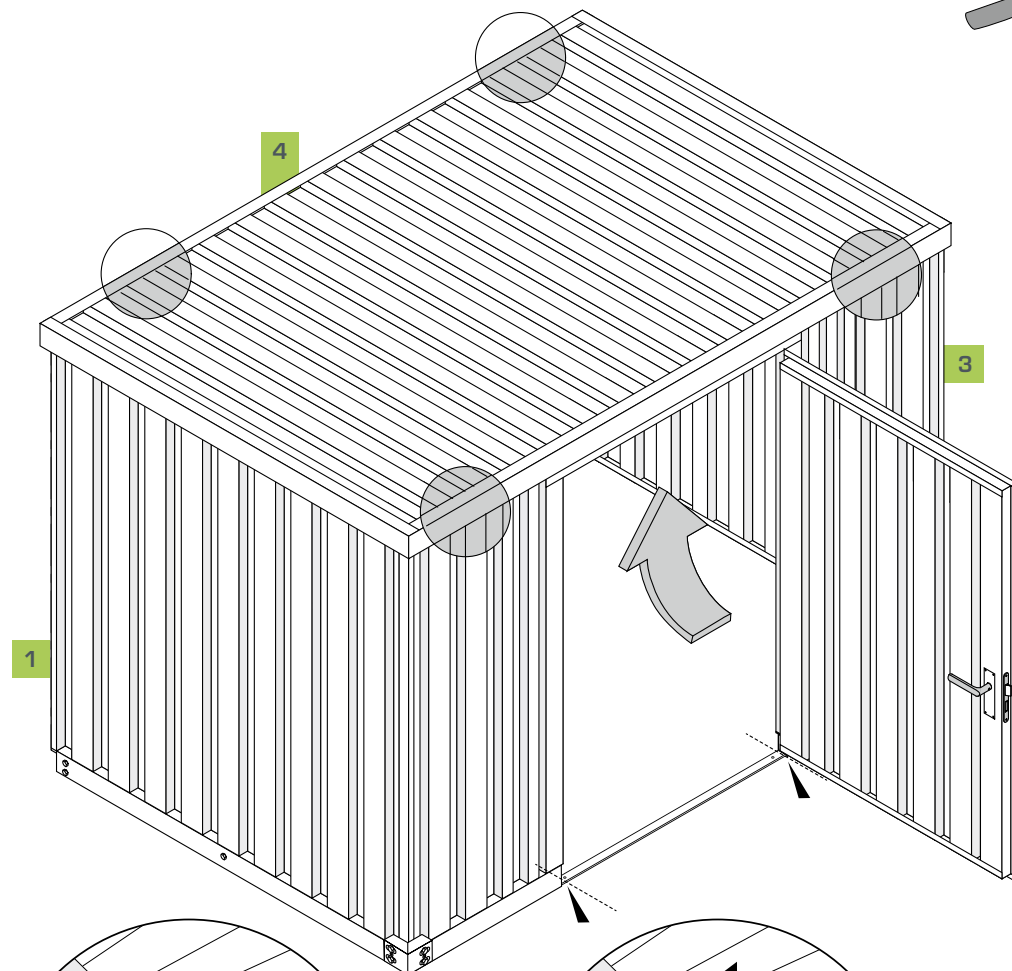
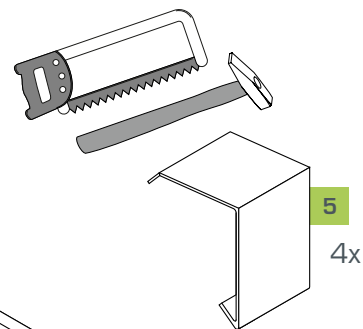

WARNUNG! EXPLOSIONSGEFAHR.
 FUNKENBILDUNG IN DER NÄHE VON
 GEFÄHRSTOFFEN (GAS ETC.) VERHINDERN.

WARNING! EXPLOSION HAZARD.
 PREVENT SPARKING IN THE VICINITY OF
 HAZARDOUS MATERIALS (GAS ETC.).

AVERTISSEMENT! DANGER D'EXPLOSION.
 ÉVITER LES ÉTINCELLES À PROXIMITÉ DE
 MATIÈRE DANGEREUSE (GAZ ETC.).

M9 Befestigungswinkel

mounting bracket | équerre de fixation

TIPP! Für leichteres Einführen der Schrauben die Löcher (Ø 5 mm) vorbohren.

HINT! For easy mounting, predrill the holes (Ø 5 mm) before inserting the screws.

CONSEIL! Pré-percer les trous (Ø 5 mm) facilite la pose des vis.

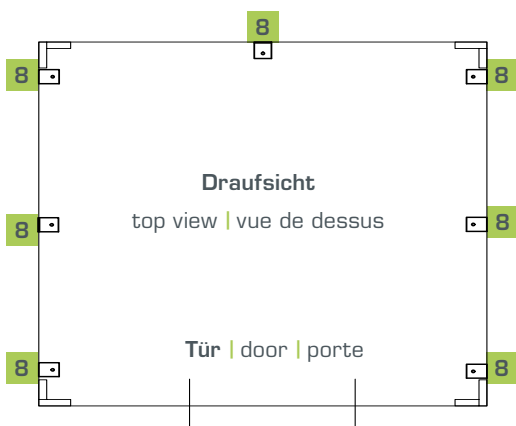
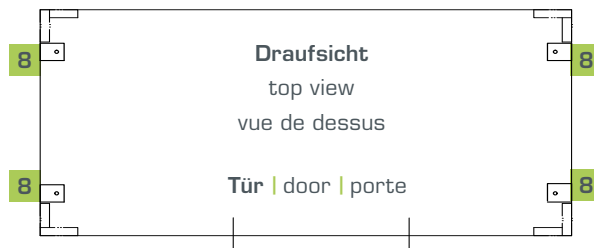
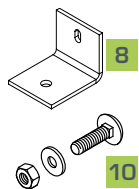

nur | only | seulement

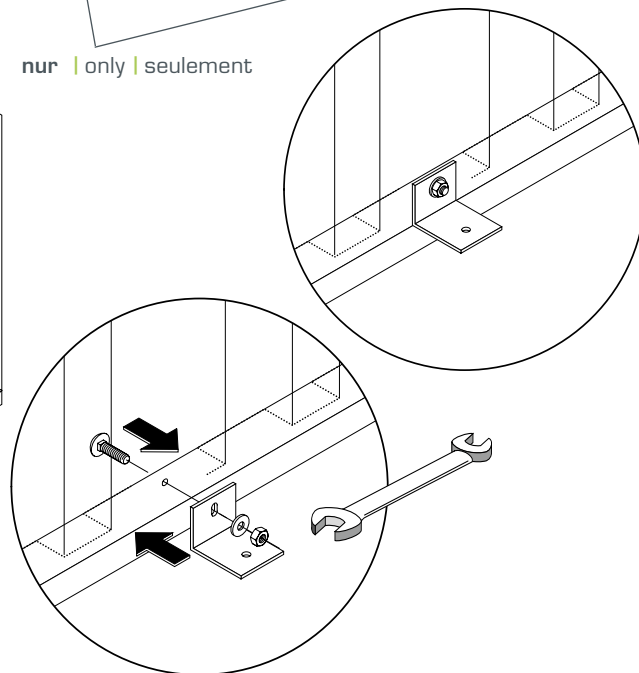
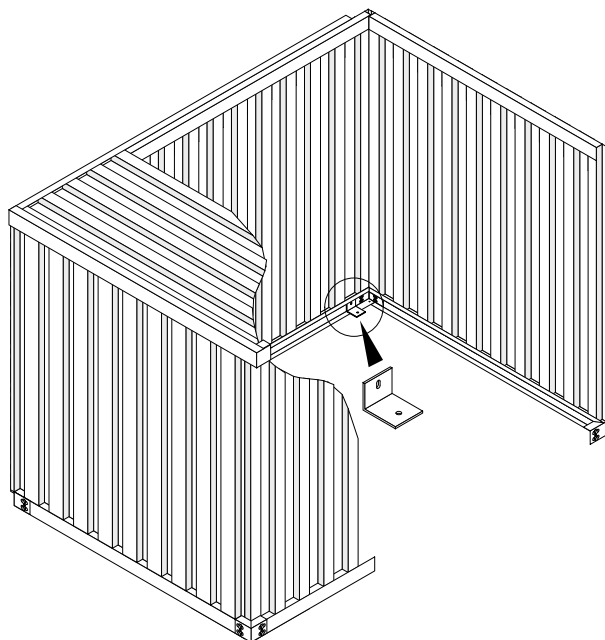

HINWEIS! Befestigungswinkel im Fundament verdübeln und verankern.

NOTICE! Dowel and anchor the mounting brackets in the foundation.

ATTENTION! Cheviller et ancrer les équerres de fixation dans la fondation.

CONTAINER ♦ **XXL**

www.container-xxl.com